

Simultane Bestimmung der Abtragsrate von definierten Coupons (Bei VLM erhältlich)

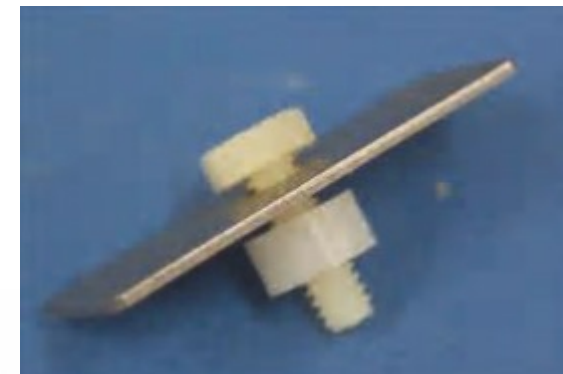
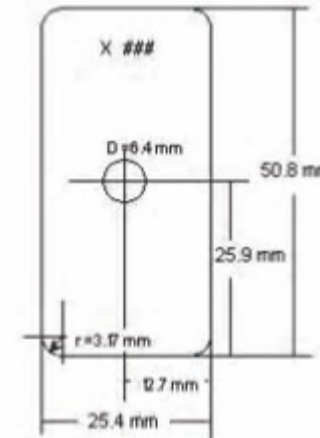

Table A2: Number of Coupons Recommended

Number of Required Cycles	Number of Coupons	Removal Frequency
≤ 10 cycles	6	5 Cycles
11 to 20 cycles	10	5 Cycles
21 to 30 cycles	14	5 Cycles
31 to 40 cycles	18	5 Cycles
41 to 80 cycles	18 ^{Note 1}	10 Cycles

Note 1: Additional coupons may be required if earlier evaluations must be conducted.

Quelle: GMW 14872 Standard



Beispiel für die Beschleunigung von Korrosionstests:

"Humidity ramp times between the ambient and wet condition and between the wet and dry conditions can have a significant effect on test acceleration (this is because corrosion rates are highest during these transition periods). "

"These ramp times can be adjusted to increase or decrease test acceleration in order to meet targeted mass loss. "

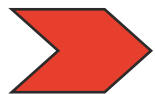

Wenn - wie dieses Beispiel zeigt - die Abtragsrate von Klima-Wechseltests durch die Bedingungen während der Übergangszeiten beeinflusst wird, so sagt das gleichzeitig, dass auf die Reproduzierbarkeit dieser Testphasen höchster Wert zu legen ist.

